

ALARM VALVE

MODEL: SDH-AVA

TECHNICAL DATA :

NOMINAL SIZE	200, 150, 100, & 80 NB	
END CONNECTION	Flange X Flange Flange X Groove Groove X Groove	
MAXIMUM WORKING PRESSURE	17.5 Bar (250 PSI)*	
THREADED OPENING	BSPT	
MOUNTING	Vertical	
FLANGE CONNECTION	ANSI B16.42 #150 (Flange drilling mtaching to ANSI B 16.5 #150)	
TRIM	Galvanised fitting with Brass Valves	
FACTORY HYDROSTATIC TEST PRESSURE	35 Kg./ Sq.cm. (500PSI)	
FRICTIONAL LOSS IN TERMS OF EQUIVALENT LENGTH OF PIPE (C-120)	200 NB	7.5 Mtrs.
	150 NB	7 Mtrs.
	100 NB	6.1 Mtrs.
	80 NB	4.7 Mtrs.
FINISH	Red RAL 3000	
ORDERING INFORMATION	Specify Size of valve, Flange Connection, Trim Details and Pipe OD	
REFERENCE	NFPA 13 and NFPA 25	

* For 200 NB FM Approval is rated upto 200PSI (14 Bar)

DESCRIPTION

Alarm Valve is a double seated clapper check valve with grooved seat design, which ensures positive water flow for alarm operation and is designed for installation in wet pipe sprinkler system. External bypass prevents false alarm under all supply pressure condition. In the event of variable pressure condition, false alarm is prevented with the provision of retard chamber, thus the design allows for installation under both variable and constant supply pressure condition.

Operation of one or more automatic fire sprinklers causes the water to flow into the sprinkler system causing the alarm valve



to open, allowing continuous flow of water into the system and transmittal of alarm, both electrical and mechanical.

OPERATION

The fire protection system initially when being pressurized, will allow water to flow into the system until the water supply and system pressure is equalized and the clapper closes the waterway. Once the pressure is stabilized, the fire protection system is ready to be placed in service and then the alarm control valve must be opened. Under normal condition, the water pressure gauge connected to the system side of the alarm valve would show a higher or equal pressure reading than the water pressure gauge connected to the supply side of the valve. This occurs because of the bypass line connecting downstream and upstream side of the alarm valve, which allows water pressure surge to pass without lifting the valve clapper off its seat, thereby causing excessive high pressure surge entrapped in the system side due to presence of a check valve, which generally prevents false alarm.

Sudden high pressure surge, as might be encountered by the start-up of a large fire pump may lead the valve clapper to lift momentarily, allowing water to flow through grooves in the valve seat to the retard

chamber. The water in the alarm line is automatically drained out, which helps to prevent false alarm due to successive transient surge in supply pressure. Restriction assembly located beneath the retard chamber consists of inlet and drain restriction orifices, which are established by considering the volume of the retard chamber to meet the listing and approval requirement with regard to time-to alarm. These requirements represent a balancing of the need to reduce the possible false alarm due to a transient surge in supply pressure and to achieve desired minimum time- to- alarm following a sprinkler operation.

In constant pressure installation, the retard chamber is not required and the water passing through the groove in the alarm valve seat flows directly through restriction nozzle assembly to activate the mechanical and electrical alarm.

INSTALLATION

1. SHIELD Sprinkler alarm valve, Model-SDH-AVA must be installed vertically.
2. The alarm valve must be installed in a readily visible and accessible location and provision to be made in such a way that alarm line drain is visible and accessible.
3. Where water pressure fluctuates, the variable pressure trim with retard chamber must be used. Under non-fluctuating water pressure condition, the constant pressure trim, which does not include retard chamber, may be used.
4. The valve must be installed with trim in accordance with the trim data. Failure to follow the appropriate trim connection guidelines may prevent the device from functioning properly as well as void listing, approval and the manufacturer's warranty.
5. Care must be exercised while installing the check valve in the trim to ascertain that they are located with the arrow mark on the check valve body and pointed in proper direction.
6. The contraction and expansion associated with an excessive volume of trapped air could cause the waterway clapper to cycle open and shut. This may result in false alarm or an intermittent alarm. To avoid these, it is recommended to have breather valve in the system piping network and a vent valve at the extreme end of the system to bleed-off the air.
7. The ball valve provided on the alarm line must be kept open and strapped in set position.
8. Pipe connecting the retard chamber and sprinkler alarm bell must be supported properly to avoid loading on the retard chamber.
9. All the newly installed system pipes must be flushed properly before alarm valve is put into service.

INSPECTION AND MAINTENANCE

A qualified and trained person must commission the system. After few initial successful tests an authorised person must be trained to perform inspection and testing of the system.

It is recommended to carry out physical inspection of the system at least twice a week. The inspection should verify that all the control valves are in proper position as per the requirement of the system and no damage has taken place to any component.

It is recommended that the alarm valve and its accessories should be examined and performed for following at least

quarterly or as demanded by local authorities to ensure reliable and trouble free operation and service.

1. Inspection and testing is to be carried out only by an authorized person. DO NOT TURN OFF the water supply valve to undertake repair work or to test the valve, without placing a roving fire patrol in the area covered by the system. The patrol should continue until the system is back into service. Also do inform the local security personnel and alarm control station, so that a false alarm is not signaled.
2. Open the alarm test valve. Verify that the sprinkler alarm bell and/or the pressure alarm switch/ electric alarm properly actuate. Close the alarm test valve and verify that water has ceased to flow from the alarm line drain.
3. Clean the 20 NB (3/4") strainer provided on the sprinkler alarm bell line.
4. Clean the strainer of restriction assembly.
5. Inspect the check valve clapper located on the bypass line.

FALSE ALARM

1. Inspect the valve rubber clapper face. If worn or damaged, replace it. Be certain that dirt, stone or any other foreign object have not accumulated under the clapper face and lodged in the groove or holes. Clean the clapper face thoroughly. If the seat ring surface is nicked or scoured, it might be possible to repair the same using lapping compound. If not, replace the complete valve or return it to the manufacturer's works for repair.
2. If sprinkler alarm bell is not functioning or the impeller is jammed, please follow the maintenance guideline provided in the catalogue for sprinkler alarm bell.
3. If pressure alarm switch gives a steady signal, but sprinkler alarm generates an intermittent alarm, check sprinkler alarm bell shaft. If both the sprinkler alarm bell and pressure alarm switch are generating intermittent alarm then check for the possible air which is trapped within the sprinkler system. Trapped air is to be bled off. Also the intermittent alarm may occur due to sudden pressure drop and increase in the system. These problems can be corrected by maintaining a steady supply.

CAUTION

1. The UL Listing, FM Approval and manufacturer's warranty are valid only when the alarm valve is installed with trim set and installed as per installation guidelines.
2. Pressure relief valve is required with wet pipe system, when a rise in ambient temperature can cause system pressure to exceed 17.5 Bar (250 PSI). A 17.7 Bar relief valve setting should be used.
3. For proper operation of the wet system and to minimize unwanted false alarm, it is important to remove trapped air from the system. The air trapped in the system may also cause intermittent operation of the Water Motor Alarm during sustained flow of water.

WEIGHT IN KG

Valve Size	Flange x Flange	Flange x Groove	Groove x Groove
200	65	54	44
150	42	35.8	28
100	27	22.1	17.3
80	18	15	12.1

GROOVE PIPE SIZE

Normal Size	Pipe OD in MM
80 NB	89
100 NB	114.3
150 NB	165.1
150 NB	168.3
200 NB	219.1

Note: For 150 NB standard supply is 168.3 mm OD pipe Groove. For 165.1mm specify in order.

NOMINAL PRESSURE LOSS VS FLOW

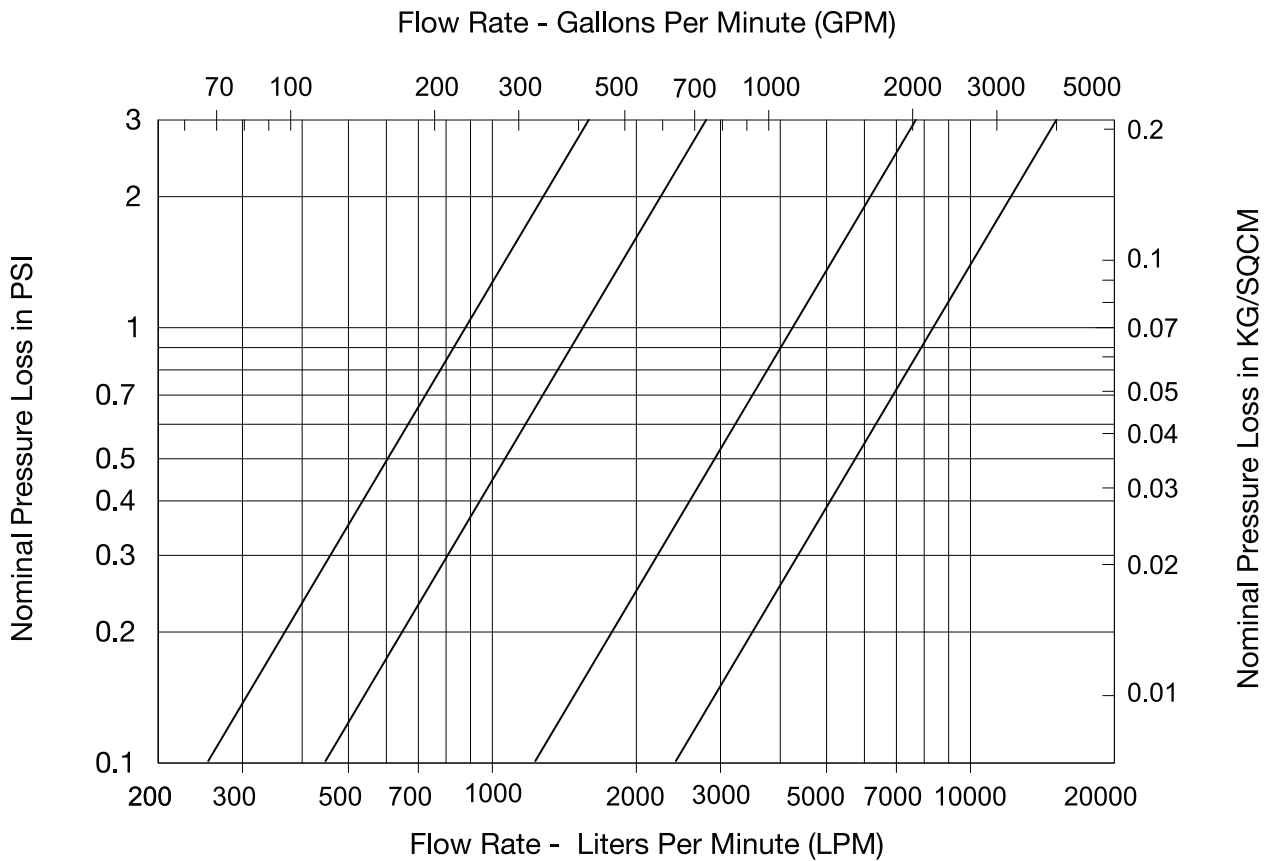

ALARM VALVE, MODEL – SDH-AVA

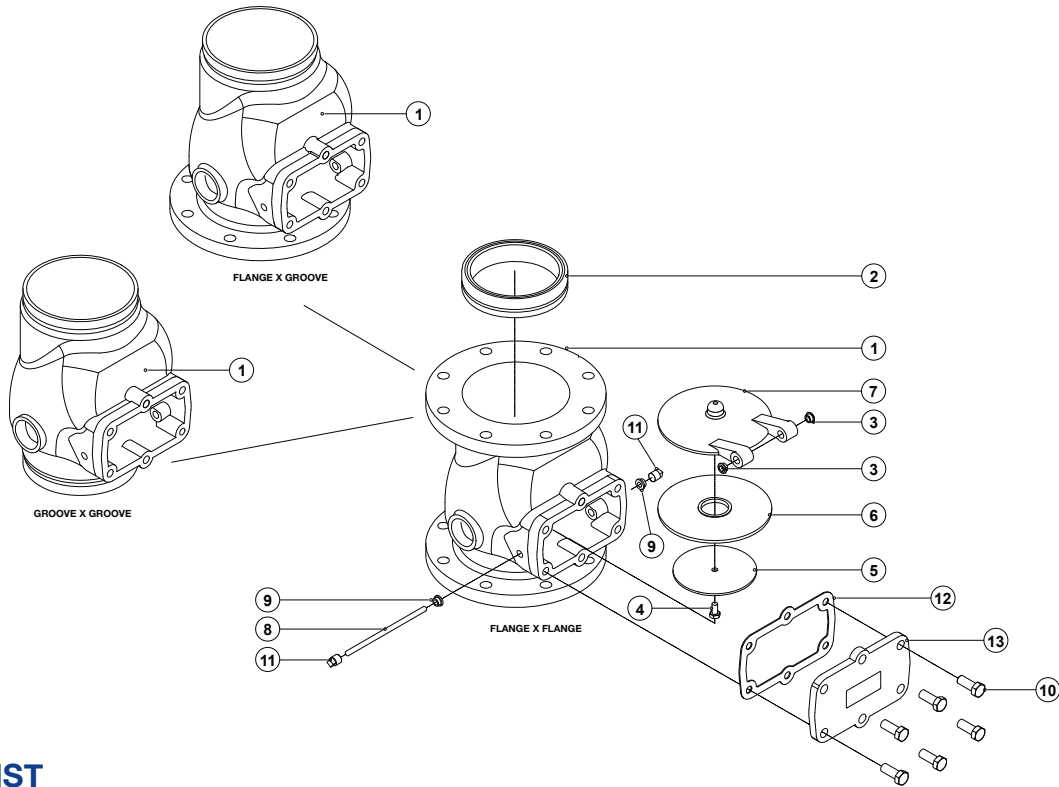

PART LIST

ITEM	PART NO.				DESCRIPTION	QTY.				MATERIAL SPECIFICATION
	200 NB	150 NB	100 NB	80 NB		200 NB	150 NB	100 NB	80 NB	
1	NA	NA	NA	NA	Housing (Flange x Flange)	1	1	1	1	Ductile Iron
1	AV2014	AV1514	AV1014	AV8014	Housing (Flange x Groove)	1	1	1	1	Ductile Iron
1	AV2014	AV1515	AV1015	AV8015	Housing (Groove x Groove)	1	1	1	1	Ductile Iron
2	NA	NA	NA	NA	Seat	1	1	1	1	Bronze
3	AV2003	AV1503	AV1003	AV8003	Clapper Bush	2	2	2	2	Brass
4	AV2004	AV1504	AV1004	AV8004	Hex. Head Bolt	4	1	1	1	Stainless Steel
5	AV2005	AV1505	AV1005	AV8005	Rubber Clamp	1	1	1	1	Stainless Steel
6	AV2006	AV1506	AV1006	AV8006	Rubber Seat	1	1	1	1	Neoprene Rubber
7	AV2007	AV1507	AV1007	AV8007	Clapper	1	1	1	1	Ductile Iron
8	AV2008	AV1508	AV1008	AV8008	Hinge Pin	1	1	1	1	Stainless Steel
9	AV2009	AV1509	AV1009	AV8009	Body Bush	2	2	2	2	Brass
10	AV2010	AV1510	AV1010	AV8010	Hex. Head Bolt	6	6	4	4	Steel
11	AV2011	AV1511	AV1011	AV8011	Sq. Head Plug	2	2	2	2	Forged Steel
12	AV2012	AV1512	AV1012	AV8012	Cover Gasket	1	1	1	1	Neoprene Rubber
13	AV2013	AV1513	AV1013	AV8013	Cover	1	1	1	1	Ductile Iron

NA: Parts replacement not available

CONSTANT PRESSURE TRIM FOR ALARM VALVE

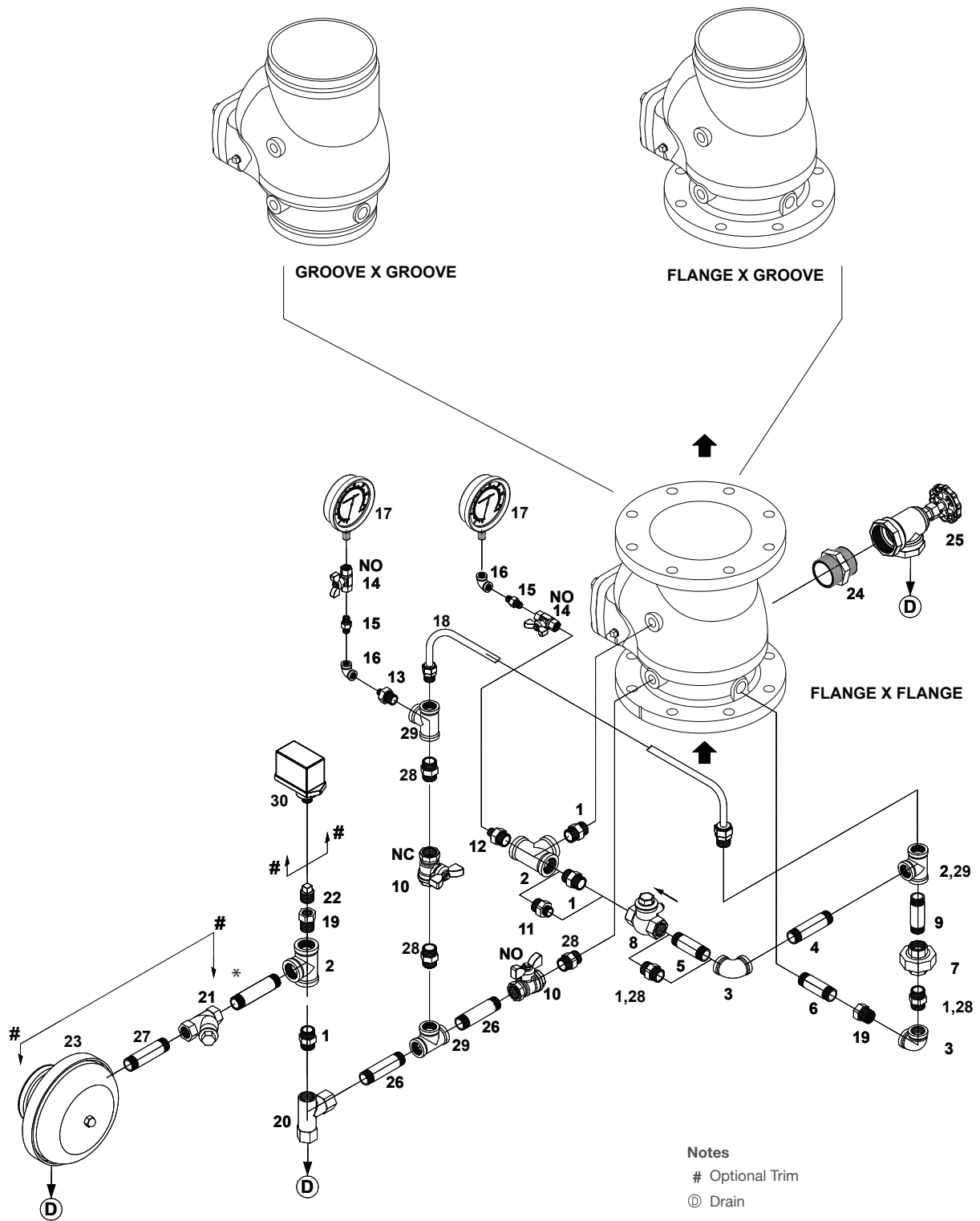

- Notes**
- # Optional Trim
 - Ⓧ Drain
 - ★ To suit at site by installer
 - NO Normally Open
 - NC Normally Closed

When pressure switch is supplied then SI.No. 22 plug not required.

CONSTANT PRESSURE TRIM FOR ALARM VALVE

ITEM NO.	CODE NO.	DESCRIPTION	SIZE	QTY			
				200NB	150 NB	100 NB	80 NB
1	AV01	Hex Nipple	3/4"	4	4	5	2
2	AV02	Tee	3/4"	3	3	3	2
3	AV03/1	Elbow	3/4"	2	2	2	---
3	AV03/2	Elbow	1/2"	---	---	---	2
4	AV04/1	Pipe Nipple	3/4" X 150 mm Long	1	---	---	---
4	AV04/2	Pipe Nipple	3/4" X 130 mm Long	---	1	---	---
4	AV04/3	Pipe Nipple	3/4" X 100 mm Long	---	---	1	---
4	AV04/4	Pipe Nipple	1/2" X 100 mm Long	---	---	---	1
5	AV05/1	Pipe Nipple	3/4" X 100 mm Long	1	---	---	---
5	AV05/2	Pipe Nipple	3/4" X 80 mm Long	---	1	---	---
6	AV06/1	Pipe Nipple	1/2" X 100 mm Long	1	---	---	1
6	AV06/2	Pipe Nipple	1/2" X 80 mm Long	---	1	1	---
7	AV07/1	Union	3/4"	1	1	1	---
7	AV07/2	Union	1/2"	---	---	---	1
8	AV08/1	Swing Check Valve	3/4"	1	1	1	---
8	AV08/2	Swing Check Valve	1/2"	---	---	---	1
9	AV09/1	Pipe Nipple	3/4" X 70 mm Long	1	1	---	---
9	AV09/2	Pipe Nipple	3/4" X 60 mm Long	---	---	1	---
9	AV09/3	Pipe Nipple	1/2" X 70 mm Long	---	---	---	1
10	AV10	Ball Valve	1/2"	2	2	2	2
11	AV11	Reducing Hex Nipple	3/4" X 1/2"	---	---	---	1
12	AV12	Reducing Hex Nipple	3/4" X 1/4"	1	1	1	1
13	AV13	Reducing Hex Nipple	1/2" X 1/4"	1	1	1	1
14	AV14	Ball Valve	1/4"	2	2	2	2
15	AV15	Hex Nipple	1/4"	2	2	2	2
16	AV16	Elbow	1/4"	2	2	2	2
17	AV17	Pressure Gauge	1/4"	2	2	2	2
18	AV18/1	Alarm Test Line Assembly	1/2"	---	---	---	1
18	AV18/2	Alarm Test Line Assembly	1/2"	---	---	1	---
18	AV18/3	Alarm Test Line Assembly	1/2"	---	1	---	---
18	AV18/4	Alarm Test Line Assembly	1/2"	1	---	---	---
19	AV19	Reducing Bush	3/4" X 1/2"	2	2	2	1
20	AV20	Restriction Nozzle Assembly	—	1	1	1	1
21	AV21	Y Type Strainer	3/4"	1	1	1	1
22	AV22	Plug	1/2"	1	1	1	1
23	AV23/1	Sprinkler Alarm	---	1	1	1	1
23	AV23/2	Sprinkler Alarm	---	1	1	1	1
24	AV24/1	Hex Nipple	2"	1	1	1	---
24	AV24/2	Hex Nipple	1 1/4"	---	---	---	1
25	AV25/1	Angle Valve	2"	1	1	1	---
25	AV25/2	Angle Valve	1 1/4"	---	---	---	1
26	AV26	Pipe Nipple	1/2" X 60 mm Long	2	2	2	2
27	AV27	Pipe Nipple	3/4" X 80 mm Long	1	1	1	1
28	AV28	Hex Nipple	1/2"	3	3	3	5
29	AV29	Tee	1/2"	2	2	2	3
30	AV30	Pressure Switch (Optional)	1/2"	1	1	1	1

VARIABLE PRESSURE TRIM FOR ALARM VALVE

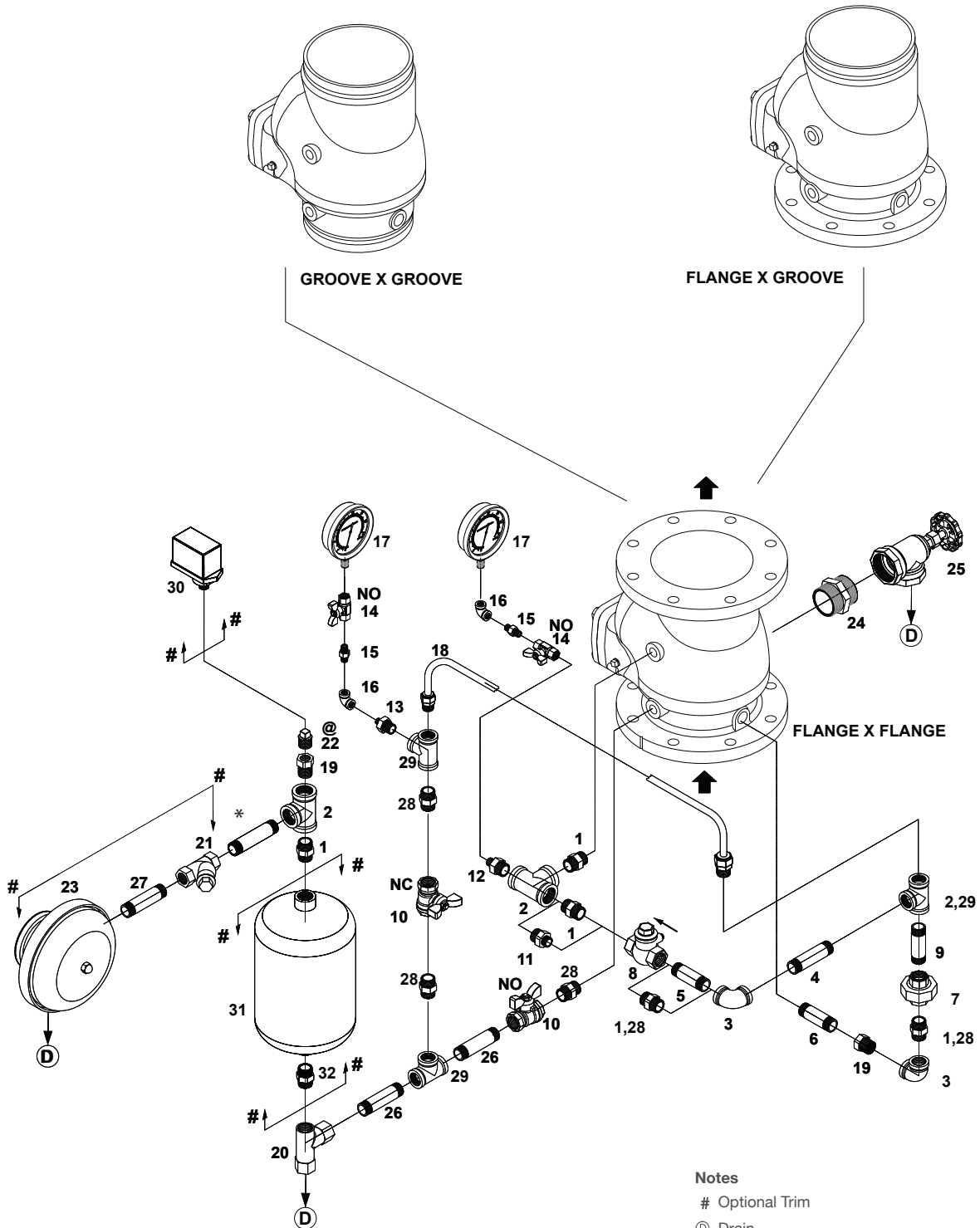

Notes

- # Optional Trim
- Ⓧ Drain
- * To suit at site by installer
- NO Normally Open
- NC Normally Closed

When pressure switch is supplied then SI.No. 22 plug not required.

VARIABLE PRESSURE TRIM FOR ALARM VALVE

ITEM NO.	CODE NO.	DESCRIPTION	SIZE	QTY			
				200NB	150 NB	100 NB	80 NB
1	AV01	Hex Nipple	¾"	4	4	5	2
2	AV02	Tee	¾"	3	3	3	2
3	AV03/1	Elbow	¾"	2	2	2	---
3	AV03/2	Elbow	½"	---	---	---	2
4	AV04/1	Pipe Nipple	¾" X 150 mm Long	1	---	---	---
4	AV04/2	Pipe Nipple	¾" X 130 mm Long	---	1	---	---
4	AV04/3	Pipe Nipple	¾" X 100 mm Long	---	---	1	---
4	AV04/4	Pipe Nipple	½" X 100 mm Long	---	---	---	1
5	AV05/1	Pipe Nipple	¾" X 100 mm Long	1	---	---	---
5	AV05/2	Pipe Nipple	¾" X 80 mm Long	---	1	---	---
6	AV06/1	Pipe Nipple	½" X 100 mm Long	1	---	---	1
6	AV06/2	Pipe Nipple	½" X 80 mm Long	---	1	1	---
7	AV07/1	Union	¾"	1	1	1	---
7	AV07/2	Union	½"	---	---	---	1
8	AV08/1	Swing Check Valve	¾"	1	1	1	---
8	AV08/2	Swing Check Valve	½"	---	---	---	1
9	AV09/1	Pipe Nipple	¾" X 70 mm Long	1	1	---	---
9	AV09/2	Pipe Nipple	¾" X 60 mm Long	---	---	1	---
9	AV09/3	Pipe Nipple	½" X 70 mm Long	---	---	---	1
10	AV10	Ball Valve	½"	2	2	2	2
11	AV11	Reducing Hex Nipple	¾" X ½"	---	---	---	1
12	AV12	Reducing Hex Nipple	¾" X ¼"	1	1	1	1
13	AV13	Reducing Hex Nipple	½" X ¼"	1	1	1	1
14	AV14	Ball Valve	¼"	2	2	2	2
15	AV15	Hex Nipple	¼"	2	2	2	2
16	AV16	Elbow	¼"	2	2	2	2
17	AV17	Pressure Gauge	¼"	2	2	2	2
18	AV18/1	Alarm Test Line Assembly	½"	---	---	---	1
18	AV18/2	Alarm Test Line Assembly	½"	---	---	1	---
18	AV18/3	Alarm Test Line Assembly	½"	---	1	---	---
18	AV18/4	Alarm Test Line Assembly	½"	1	---	---	---
19	AV19	Reducing Bush	¾" X ½"	2	2	2	1
20	AV20	Restriction Nozzle Assembly	---	1	1	1	1
21	AV21	Y Type Strainer	¾"	1	1	1	1
22	AV22	Plug	½"	1	1	1	1
23	AV23/1	Sprinkler Alarm	---	1	1	1	1
23	AV23/2	Sprinkler Alarm	---	1	1	1	1
24	AV24/1	Hex Nipple	2"	1	1	1	---
24	AV24/2	Hex Nipple	1¼"	---	---	---	1
25	AV25/1	Angle Valve	2"	1	1	1	---
25	AV25/2	Angle Valve	1¼"	---	---	---	1
26	AV26	Pipe Nipple	½" X 60 mm Long	2	2	2	2
27	AV27	Pipe Nipple	¾" X 80 mm Long	1	1	1	1
28	AV28	Hex Nipple	½"	3	3	3	5
29	AV29	Tee	½"	2	2	2	3
30	AV30	Pressure Switch (Optional)	½"	1	1	1	1
31	AV31	Retard Chamber, Model - RC9	---	1	1	1	1
32	AV32	Hex Nipple	¾"	1	1	1	1

CONSTANT PRESSURE TRIM - SCHEMATIC FLANGE X FLANGE

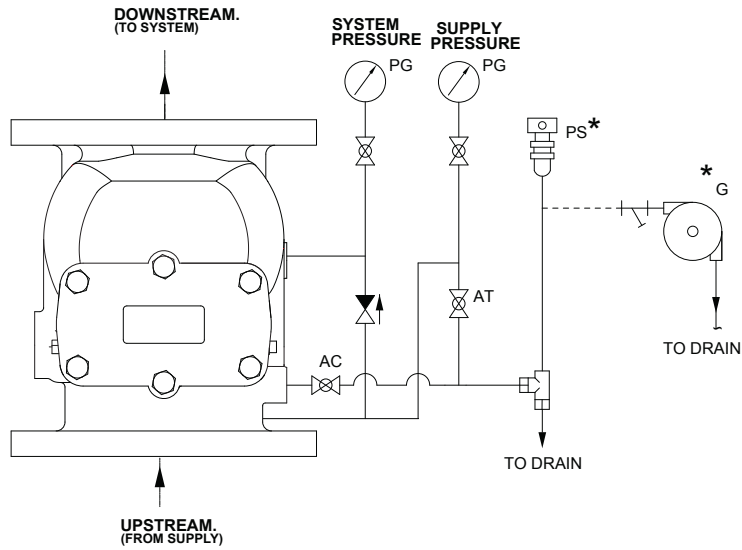

VARIABLE PRESSURE TRIM - SCHEMATIC FLANGE X FLANGE

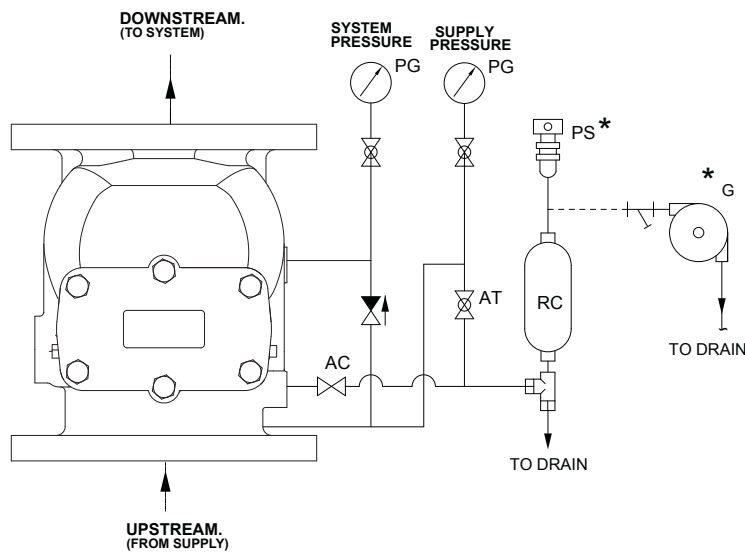

Abbreviation & Symbols

▶◀	Non Return Valve	⌞	Stop Valve	AV	Alarm Valve
⊗	Valve	AC	Sprinkler Alarm Control Valve	G	Sprinkler Alarm
⊘	Angle Valve	★	Optional	PS	Pressure Switch
⌞	Strainer	NO	Normally Open	RC	Retard Chamber
NC	Normally Closed	OD	Open Drain	AT	Sprinkler Alarm Test Valve
⊞	Restriction Nozzle Assembly	PG	Pressure Gauge	---	By User

NOTE:-

1) Sprinkler alarm control valve must be kept normally open if this valve is kept closed the sprinkler alarm bell/electric alarm will not signal.

2) Sprinkler alarm test valve must be kept normally closed condition. Valve is opened to test the sprinkler alarm bell/electrical alarm.

CONSTANT PRESSURE TRIM - SCHEMATIC FLANGE X GROOVE

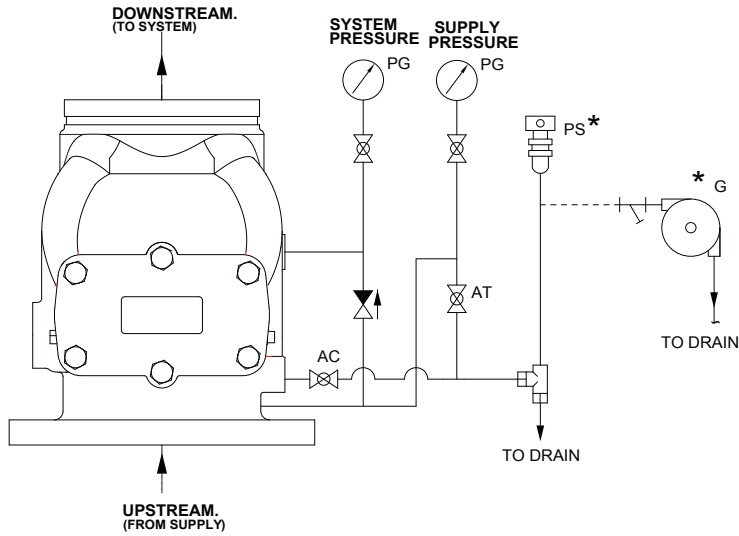

VARIABLE PRESSURE TRIM - SCHEMATIC FLANGE X GROOVE

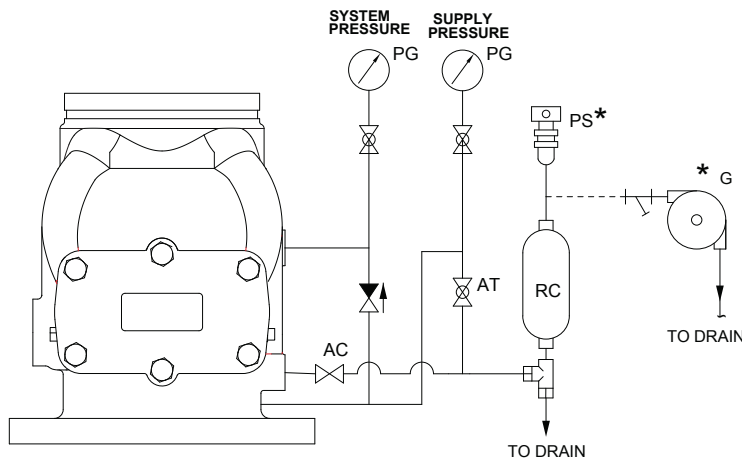

Abbreviation & Symbols

▶	Non Return Valve	⊥	Stop Valve	AV	Alarm Valve
⊗	Valve	AC	Sprinkler Alarm Control Valve	G	Sprinkler Alarm
⊘	Angle Valve	★	Optional	PS	Pressure Switch
⊘	Strainer	NO	Normally Open	RC	Retard Chamber
NC	Normally Closed	OD	Open Drain	AT	Sprinkler Alarm Test Valve
⊘	Restriction Nozzle Assembly	PG	Pressure Gauge	---	By User

NOTE:-

1) Sprinkler alarm control valve must be kept normally open if this valve is kept closed the sprinkler alarm bell/electric alarm will not signal.

2) Sprinkler alarm test valve must be kept normally closed condition. Valve is opened to test the sprinkler alarm bell/electrical alarm.

CONSTANT PRESSURE TRIM - SCHEMATIC GROOVE X GROOVE

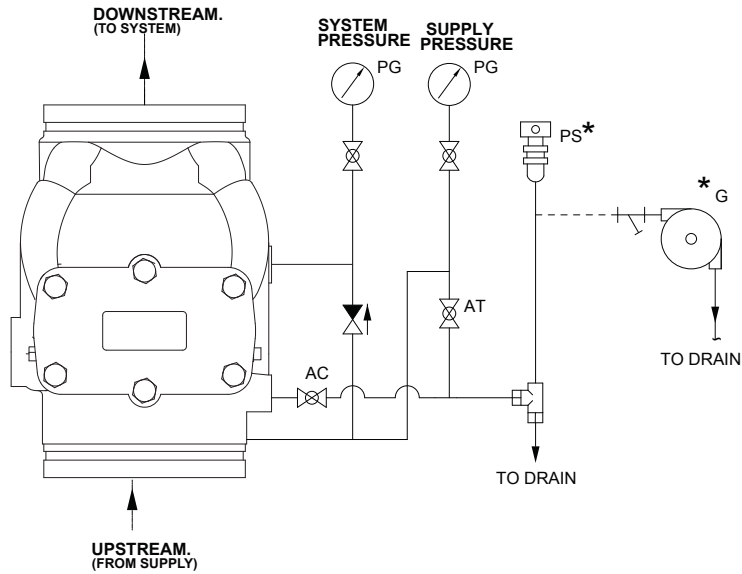

VARIABLE PRESSURE TRIM - SCHEMATIC GROOVE X GROOVE

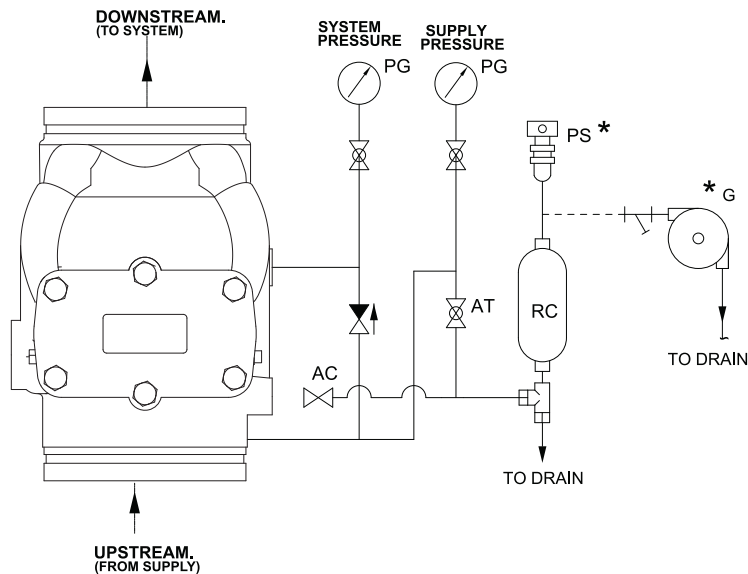

Abbreviation & Symbols

▶◀	Non Return Valve	⌞	Stop Valve	AV	Alarm Valve
⊗	Valve	AC	Sprinkler Alarm Control Valve	G	Sprinkler Alarm
⌞	Angle Valve	★	Optional	PS	Pressure Switch
⌞	Strainer	NO	Normally Open	RC	Retard Chamber
NC	Normally Closed	OD	Open Drain	AT	Sprinkler Alarm Test Valve
⌞	Restriction Nozzle Assembly	PG	Pressure Gauge	---	By User

NOTE:-

1) Sprinkler alarm control valve must be kept normally open if this valve is kept closed the sprinkler alarm bell/electric alarm will not signal.

2) Sprinkler alarm test valve must be kept normally closed condition. Valve is opened to test the sprinkler alarm bell/electrical alarm.

INSTALLATION DIMENSION WITH TRIM FLANGE X FLANGE

A) Constant Pressure Trim

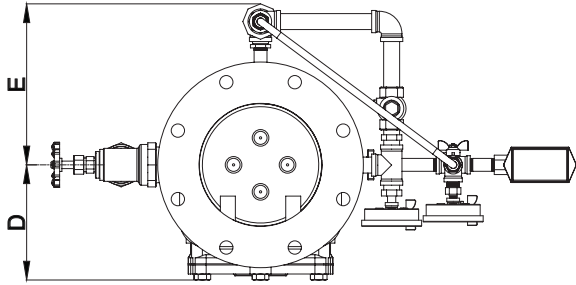

WITH CONSTANT PRESSURE TRIM				
SIZE	80 NB	100 NB	150 NB	200 NB
A	279	312	331	350
B	457	464	486	527
C	434	434	434	443
D	127	140	173	192
E	201	219	234	269
F	262	274	320	378

Unit : mm

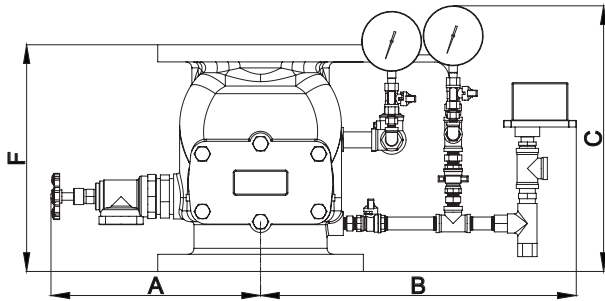

B) Variable Pressure Trim

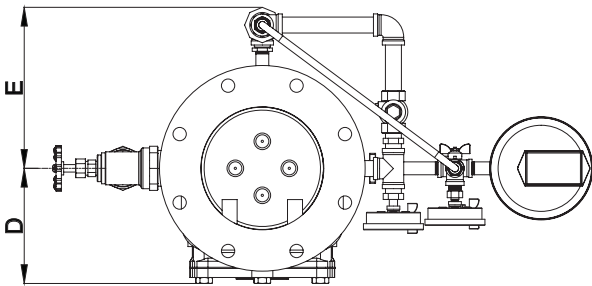

WITH VARIABLE PRESSURE TRIM				
SIZE	80 NB	100 NB	150 NB	200 NB
A	279	312	331	350
B	482	488	510	551
C	588	588	588	597
D	127	140	173	192
E	201	219	234	269
F	262	274	320	378

Unit : mm

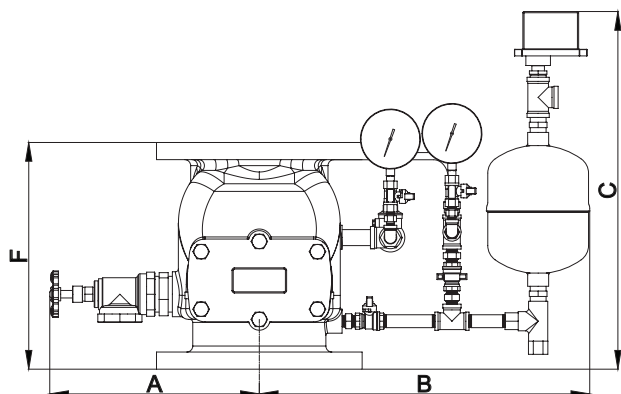

INSTALLATION DIMENSION WITH TRIM FLANGE X GROOVE

A) Constant Pressure Trim

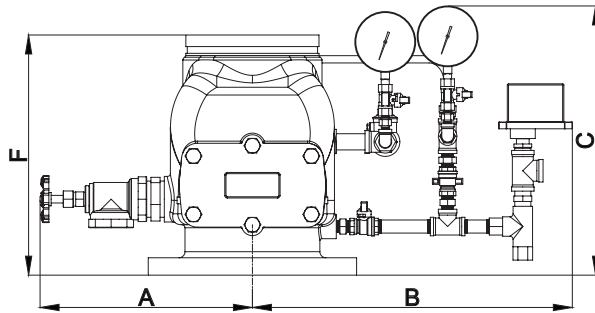
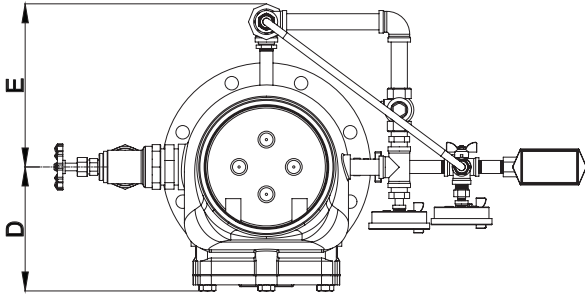

WITH CONSTANT PRESSURE TRIM				
SIZE	80 NB	100 NB	150 NB	200 NB
A	279	312	331	350
B	457	464	486	527
C	434	434	434	443
D	127	140	173	204
E	201	219	234	269
F	275	291	317	395

Unit : mm

B) Variable Pressure Trim

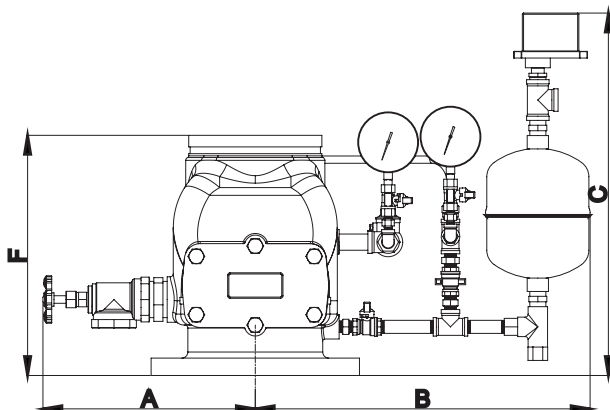
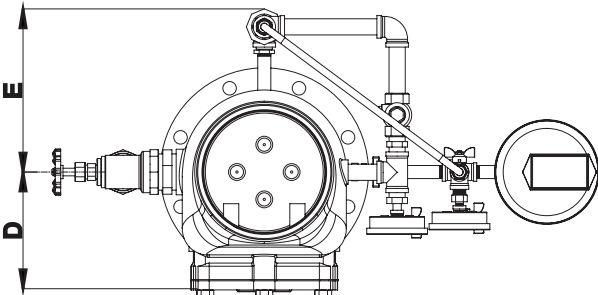

WITH VARIABLE PRESSURE TRIM				
SIZE	80 NB	100 NB	150 NB	200 NB
A	279	312	331	350
B	482	488	510	551
C	588	588	588	597
D	127	140	173	204
E	201	219	234	269
F	275	291	317	395

Unit : mm

INSTALLATION DIMENSION WITH TRIM GROOVE X GROOVE

A) Constant Pressure Trim

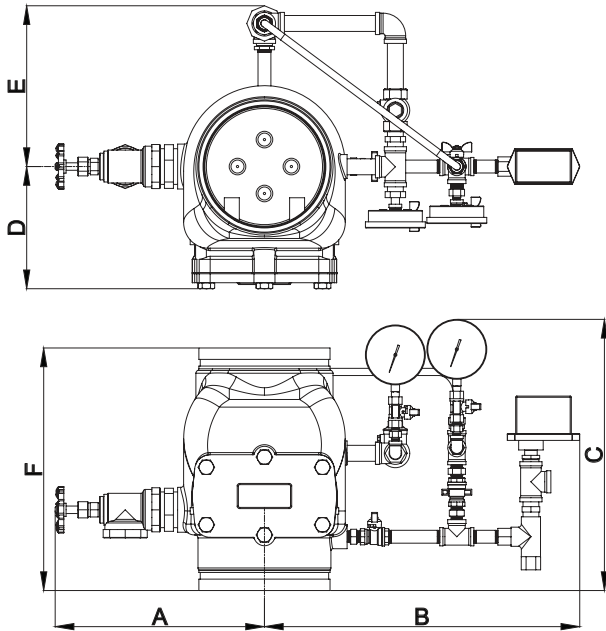

WITH CONSTANT PRESSURE TRIM				
SIZE	80 NB	100 NB	150 NB	200 NB
A	279	312	331	350
B	457	464	486	527
C	434	434	434	443
D	127	140	173	204
E	201	219	234	269
F	280	300	324	405

Unit : mm

B) Variable Pressure Trim

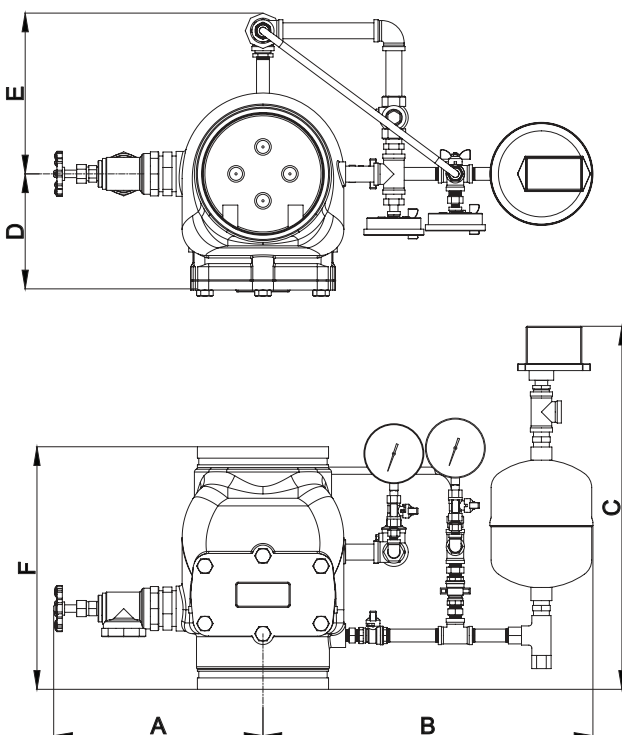

WITH VARIABLE PRESSURE TRIM				
SIZE	80 NB	100 NB	150 NB	200 NB
A	279	312	331	350
B	482	488	510	551
C	588	588	588	597
D	127	140	173	204
E	201	219	234	269
F	280	300	324	405

Unit : mm

RETARD CHAMBER

MODEL: RC9

TECHNICAL DATA :

MATERIAL	Stainless Steel
CONNECTION	3/4" BSPT (F)
WEIGHT	2.6 Kg
RATED PRESSURE	17.5 Bar (250 PSI)

APPLICATION

Retarding Chamber is used with Alarm Valve Trim when variable pressure is anticipated in the system. It is a holding tank to prevent activation of the Sprinkler Alarm during water pressure surge, but permits the activation of alarm on sustained flow. The Retarding Chamber is part of UL Listed and FM Approved Alarm Valve Trim. The Retarding Chamber is made of stainless steel material and rated for 17.5 bar pressure.

OPERATION

Due to sprinkler operation, water starts flowing and clapper of Alarm Valve opens, allowing the water flow to Sprinkler Alarm port. The Sprinkler Alarm port is connected to Retarding Chamber through Restriction Nozzle assembly.

When the flow through inlet of Restriction Nozzle exceeds the drain nozzle flow, the Retarding Chamber begins to fill and there by flowing to sprinkler alarm and pressure switch to activate the alarm. Use of Retarding Chamber prevents the false alarm in variable pressure system.

MAINTENANCE

The Restriction Nozzle assembly needs to be inspected and cleaned for possible blockage of Orifice and Screen. More frequent cleaning may be required depending on water quality with respect to water borne debris. The owner is solely responsible for maintaining their fire protection system and devices in proper operating condition.



SPRINKLER ALARM

MODEL: SDGA

TECHNICAL DATA :

MOUNTING TYPE	Type - A & Type - B
WATER WORKING PRESSURE	17.5 Bar (250 PSI)
CONNECTION	Inlet: 3/4" BSPT (3/4" NPT) Drain: 1" BSPT (1" NPT)
GONG DIAMETER	205mm (8")
GONG DEPTH	50mm (2")
FINISH	Red RAL 3000
WEIGHT	3 Kg.
ORDERING INFORMATION	Mounting Type



DESCRIPTION

SHIELD Sprinkler Alarm is a hydraulically driven mechanical bell. It does sound a continuous alarm when the sprinkler system operates. The impeller and drive shaft are energy efficient, made from light weight nonmetallic material and do not require any external lubrication. The gong, protection cover and motor housing are made of corrosion resistant aluminium alloy.

Sprinkler Alarm with mounting Type-B is wall mounting type. Type-B is suitable for 50 to 250 mm thick wall and curves with 325 mm long drive shaft as standard supply. For wall thickness 250 to 450 mm or longer a special extension drive shaft can be supplied on request.

OPERATION

When the sprinkler system is activated by the fusing of one or more automatic sprinklers at fire condition, the water flows through the Alarm Valve/Deluge Valve and enters the sprinkler alarm through the nozzle, creating a high velocity jet which strikes the impeller causing the drive shaft and the striker arm assembly to rotate. The alarm arm assembly rotates and strikes to impact against the aluminium gong, producing a continuous alarm. The waste water then drains out through a 25NB drain outlet.

DESIGN REQUIREMENT

Strainer is required in the Sprinkler Alarm line to protect the 3.2 mm nozzle in the water motor housing from clogging.

The alarm line pipe must be 20NB (3/4") size with 22.8 mtrs. (75 feet) maximum total length of pipe with minimum number of fittings. If the length of the pipe exceeds 22.8 mtrs. (75 feet), then higher size pipe must be used to reduce hydraulic friction loss. The Sprinkler Alarm should not be located more than 1.8 mtrs. (Six feet) above Alarm Valve / Deluge Valve.

One Sprinkler Alarm may be connected to one or maximum of three alarm lines of separate fire systems. For interconnecting more than one Sprinkler Alarm, a swing check valve in each line need to be provided.

MAINTENANCE

Qualified and trained person must commission the system. After few initial successful tests an authorised person must be trained to perform inspection and testing of the system.

Even though corrosion resistant material is used in the construction of the Sprinkler Alarm, it is suggested that the Sprinkler Alarm be examined and tested at regular intervals to ensure that the nozzle is free from obstruction and the impeller is free to rotate. The inspection should include the following, in addition to any specific requirement of NFPA, or as required by authority having jurisdiction.

1. Clean the 20 NB (3/4") Strainer provided in the alarm line.
2. Open the 3/8" plug provided on the inlet of the Sprinkler Alarm and clean out any accumulated particles.
3. Detach the Gong, clean the internal surface and refit in proper sequence.
4. Activate the Sprinkler Alarm to verify clear and steady sound.

INSTALLATION OF SPRINKLER ALARM MOUNTING TYPE - A

The Sprinkler Alarm with mounting Type-A is supplied pre-assembled. Connect the Alarm port of the Alarm valve or Deluge valve to the inlet of the sprinkler alarm assembly with 20NB (3/4") pipe with proper support.

A 20NB (3/4") strainer is to be provided as close as possible to the Sprinkler Alarm assembly. Connect the 25NB (1") drain pipe to the housing, taking due care that the drain discharge is running to a safe location and keep the drain free from obstruction. A blocked drain discharge may create back pressure and prevent the Sprinkler Alarm from operating properly.

The 20NB (3/4") inlet and 25NB (1") drain pipe should be properly supported with the help of the bracket so that in turn proper support is available for the Sprinkler Alarm. The inlet and the drain pipe is to be preferably connected with an union for easy removal and re-fixing of the Sprinkler Alarm during maintenance.

The Sprinkler Alarm must be installed in accordance with the requirement of NFPA, TAC or to the requirement of the local authority having jurisdiction.

INSTALLATION OF SPRINKLER ALARM MOUNTING TYPE - B

1. Locate and cut a hole through the building wall to accommodate a 20NB (3/4") pipe with coupling (galvanised pipe to be supplied by the installer). The required length of support pipe is equal to the thickness of the wall minus 30 millimetres. The pipe is to be threaded with standard 20NB (3/4") pipe threading on both the ends to a length of 20 millimetres. Cut the drive shaft length, equal to the wall thickness plus 43 millimeters.

2. Insert one end of the drive shaft into the square hole provided in the impeller of the Sprinkler Alarm gong assembly. One end of 20NB (3/4") support pipe is to be screwed to the coupling provided with the assembly and the other end of the pipe is to be screwed to the housing of the Sprinkler Alarm motor assembly as shown in the figure. Position this assembly against the building wall through a washer with the support pipe extending through the wall.

3. Connect the alarm port of the Alarm Valve or Deluge Valve to the inlet of the Sprinkler Alarm assembly with 20NB (3/4") pipe, with proper support. A 20NB (3/4") strainer is to be provided as close as possible to the Sprinkler Alarm assembly.

4. Move to the other side of the wall, place protection cover on to the pipe coupling (screwed to the pipe) and hold against the wall. Insert the bush (assembly with drive shaft adaptor) into the hole provided in the protection cover and thereby hand tighten the coupling extending through the wall. Make sure that the drive shaft is properly fitted in the square hole of impeller and drive shaft adaptor. This can be ensured by rotating the drive shaft adaptor. The drive shaft adaptor should rotate without any binding while tightening the bush. If any binding is noticed then unscrew the bush and refit. After ensuring that the drive shaft is properly placed in the square holes at both ends, wrench tight the bush.

5. Place the gong over the gong post with washers as shown in the cross-sectional drawing and hand tighten the dome nut, rotate the gong until the lettering is properly originated. Wrench tighten the dome nut.

6. Connect the 25NB (1") open drain pipe to the motor housing, taking due care that the drain discharge is running to a safe location and keep it free from obstruction.

SPRINKLER ALARM - SDGA MOUNTING TYPE - A

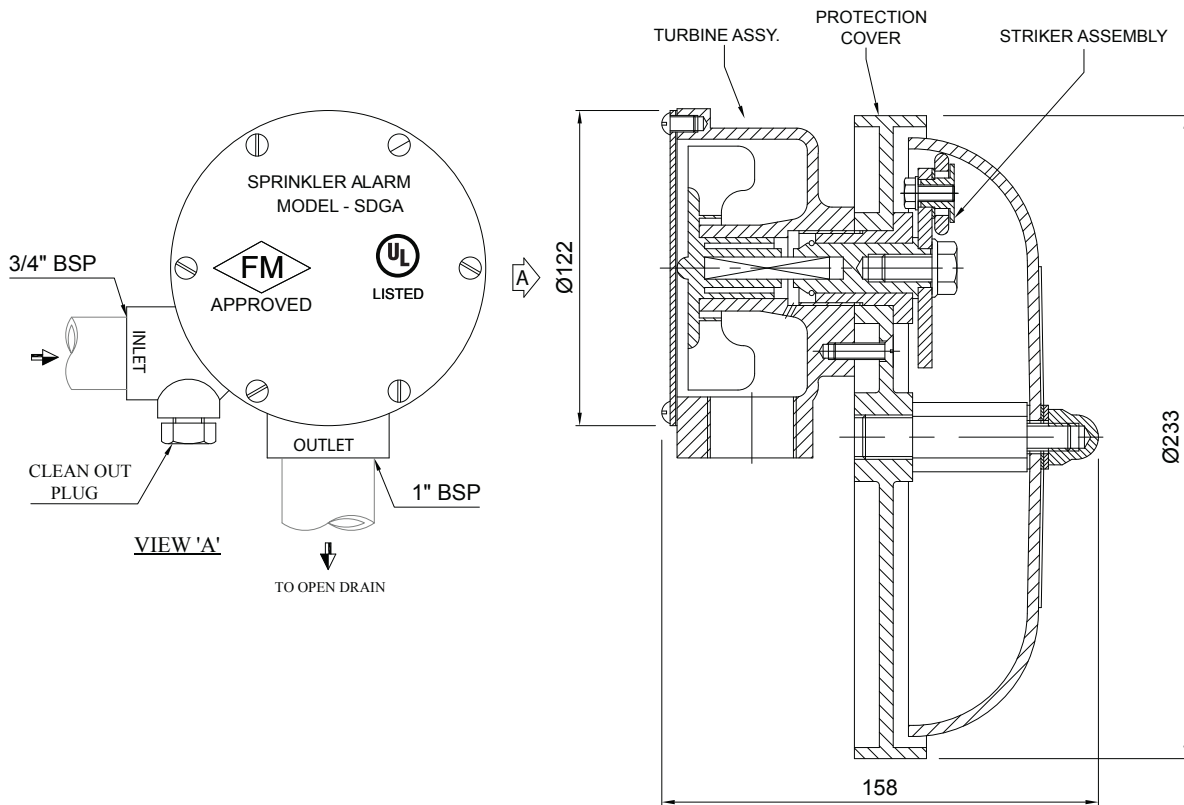

SPRINKLER ALARM - SDGA MOUNTING TYPE - B

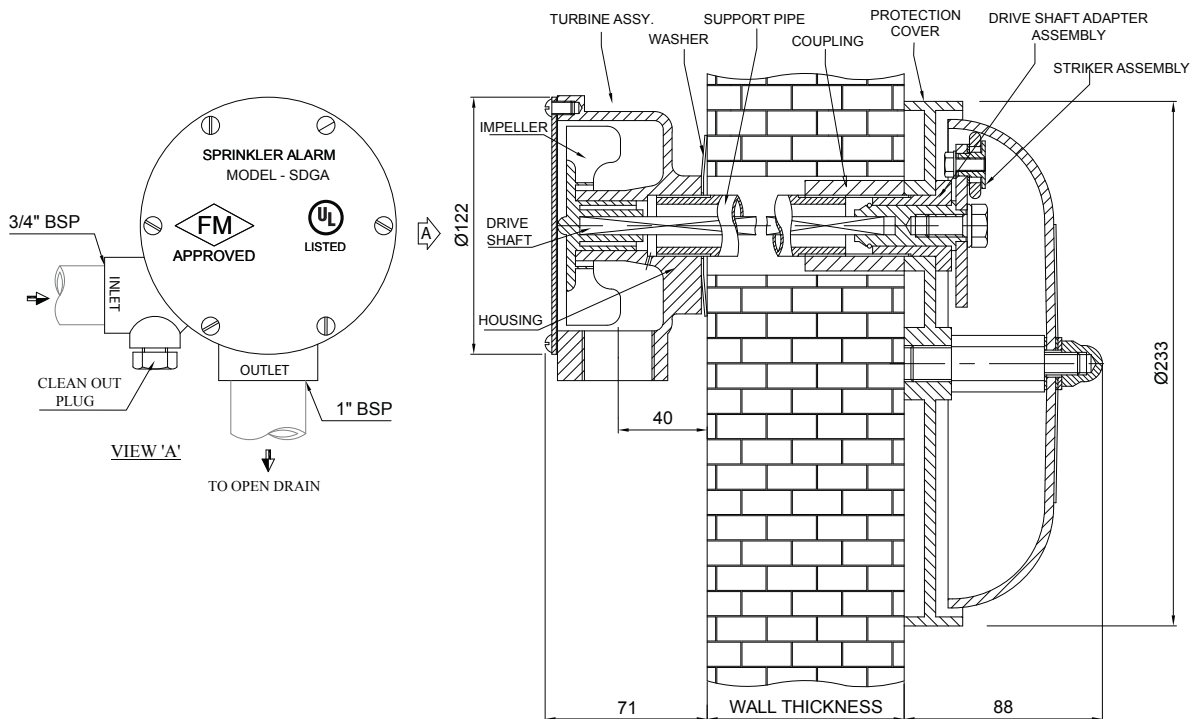

Note: All dimensions in mm unless otherwise specified